

MIXPRO 50 STANDARD complete continuous mixing machine - 400V 50 Hz - Chassis

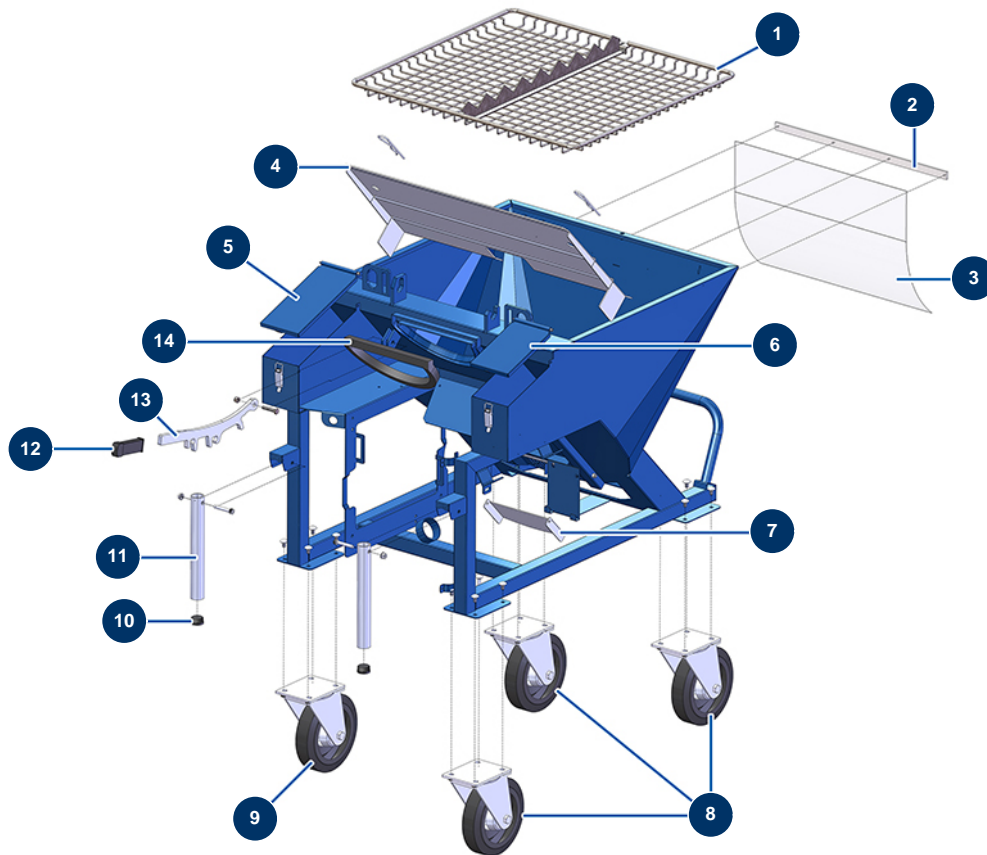

Détails des pièces

Pos.	Référence	Désignation
1	MI7017502000	PLUS TOP safety grid
2	MI4906519000	
3	MI4920001010	MIXPRO 28 compressor protection plastic
4	C23633	4
5	MI400201500A	MIXPRO 50 large drawer cover
6	MI400201400A	MIXPRO 50 small drawer cover
7	MI401700110A	
8	MI3F00300902	Pivot wheel without brake
9	MI3F00300901	Pivot wheel with brake
10	MI3F00400400	Black PVC plug
11	MI4914001000	MIXPRO 30 & 50 machine arm
12	MI3T02700201	Rubber handle
13	MI4928001000	

Pos.	Référence	Désignation
14	MI3G01000151	Motor support gasket by the metre

MIXPRO 50 STANDARD complete continuous mixing machine - 400V 50 Hz - Dosage group

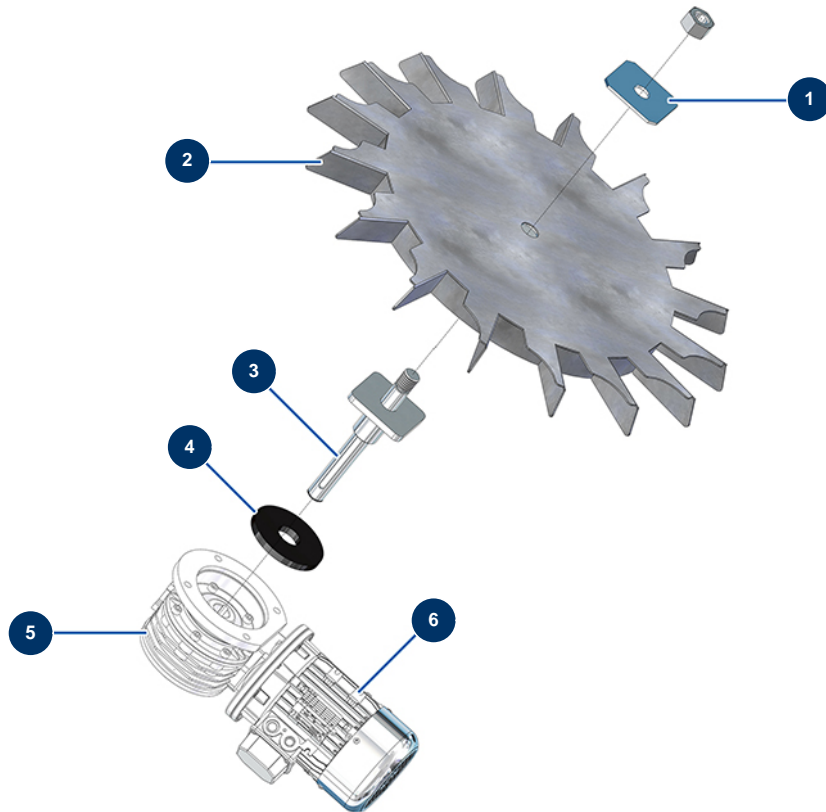

Détails des pièces

Pos.	Référence	Désignation
1	MI4912001100	
2	MI7019006000	Paddle wheel for PLUS CLASSIC, STANDARD, TOP and MONO vers. 2020
3	MI7015002000	MIXPRO 30 & 50 powder wheel shaft
4	MI4920003000	MIXPRO 30 & 50 powder wheel O-ring
5	MI3D00300312	T63 - R67 gear reducer
6	MI3D00200201	Electric motor 0,55 kW - T71 - B5 - 1400 rpm - 400V

MIXPRO 50 STANDARD complete continuous mixing machine - 400V 50 Hz - Mixing group

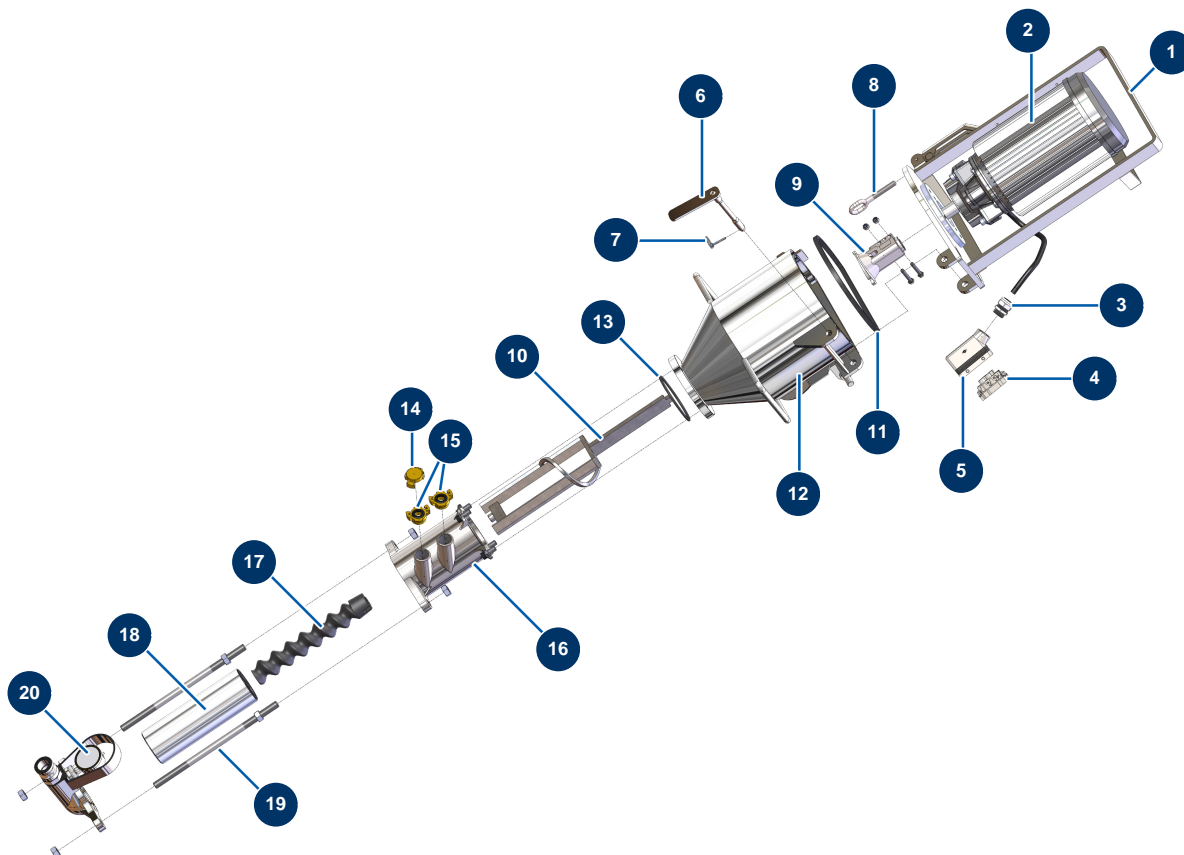

Détails des pièces

Pos.	Référence	Désignation
1	MI7011003000	PLUS Motor Support
2	MI3D00420100	CAMIX 5,5 KW 400V geared motor
3	MI3C04200208	PG21 cable gland
4	MI3C03100400	Male motor safety socket
5	MI3C02800100	Mobile Base
6	MI7018006000	Engine locking axis
7	MI3T01200101	Clip pin
8	MI3T01000400	Motor Closing Ring
9	MI700600600S	PLUS TRI/ MIXPRO 50 motor coupling
10	MI7003019000	MIXER PLUS mixing shaft
11	MI3G01000151	Motor support gasket by the metre
12	MI701400200S	MIXER PLUS mixing chamber
13	MI3G01000301	O-ring

Pos.	Référence	Désignation
14	MI3A00100401	Geka coupling plug
15	MI3A00100304	1" GEKA male coupling
16	MI7021004000	MIXPRO 28 mixing chamber
17	MI7009049200	MIXER 1 D6-3 long life pump rotor
18	MI3F00502200	MIXER 1 pump stator
19	MI8023003000	M16 tie rod L = 350 mm + screws
20	MI8012005000	PLUS/MUSTANG complete pump head

MIXPRO 50 STANDARD complete continuous mixing machine - 400V 50 Hz - Air group

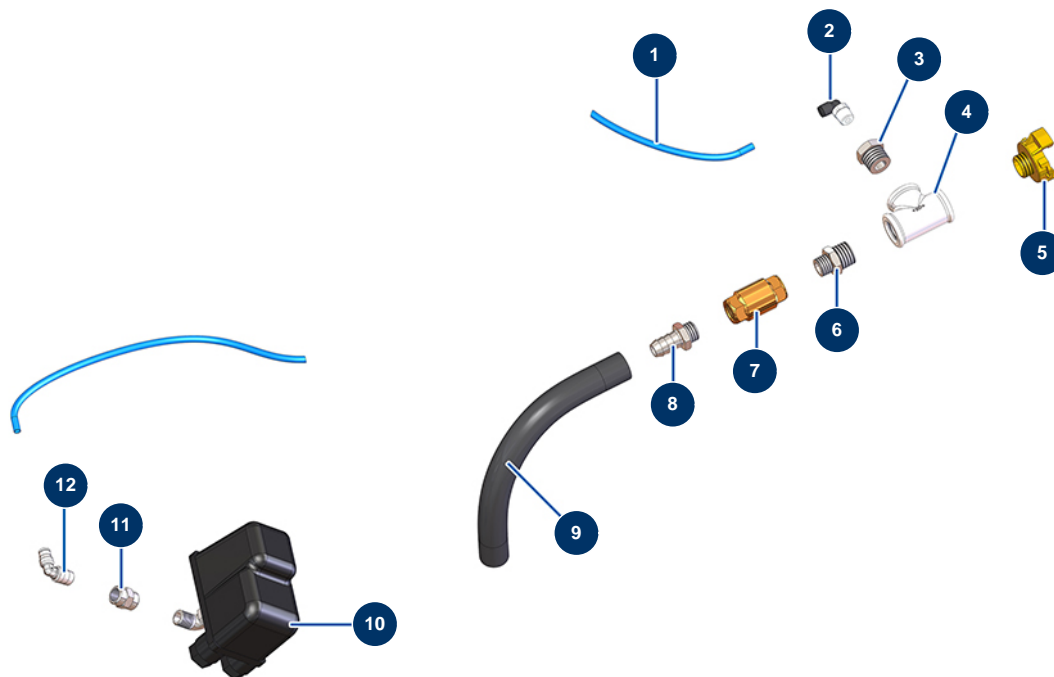

Détails des pièces

Pos.	Référence	Désignation
1	MI3G50500100	Calibrated polyurethane tube ø 4 x 6 black by the metre
2	MI3G50200200	
3	MI3G50300100	1/2" MaleC x 1/4" FemaleC galvanised reduction
4	MI3G00513002	Galvanised T F1/2" x F1/2" x F1/2"
5	MI3A00100302	1/2" outer threaded Geka coupling
6	MI3G50300700	3/8" MaleC x 1/2" MaleC low-pressure nipple
7	MI3G01300401	3/8" non-return valve
8	MI3G50300202	Threaded connection 3/8" corrugated ø 14
9	MI3F00700210	Rubber hose 13x19 black
10	MI3G00403106	Pressure switch PT/5 - 0.6-2 Bar
11	MI3G50300900	1/4" FemaleD x 1/4" FemaleD x 30 low-pressure nipple
12	MI3G50300400	

KPRO 50 STANDARD complete continuous mixing machine - 400V 50 Hz - Compressor gro

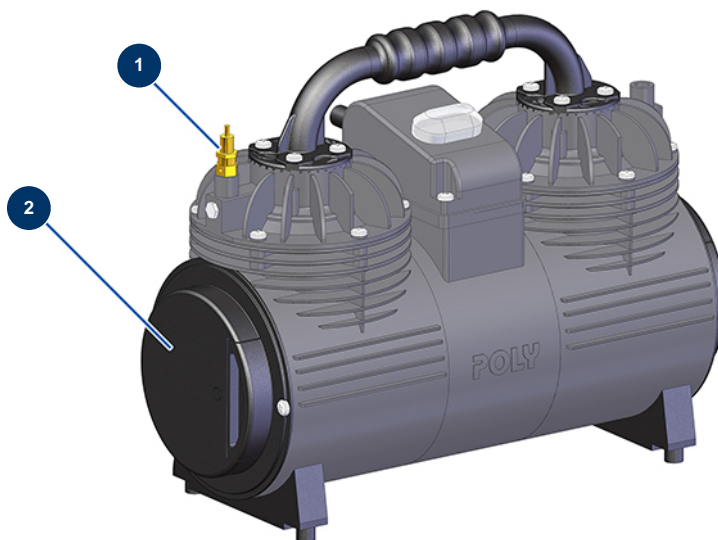

Détails des pièces

Pos.	Référence	Désignation
1	MI3G01300304	Safety Valve 1/4 3 bar
2	MI3B02900120	BORA compressor air filter - 2015 version

MIXPRO 50 STANDARD complete continuous mixing machine - 400V 50 Hz - Water group

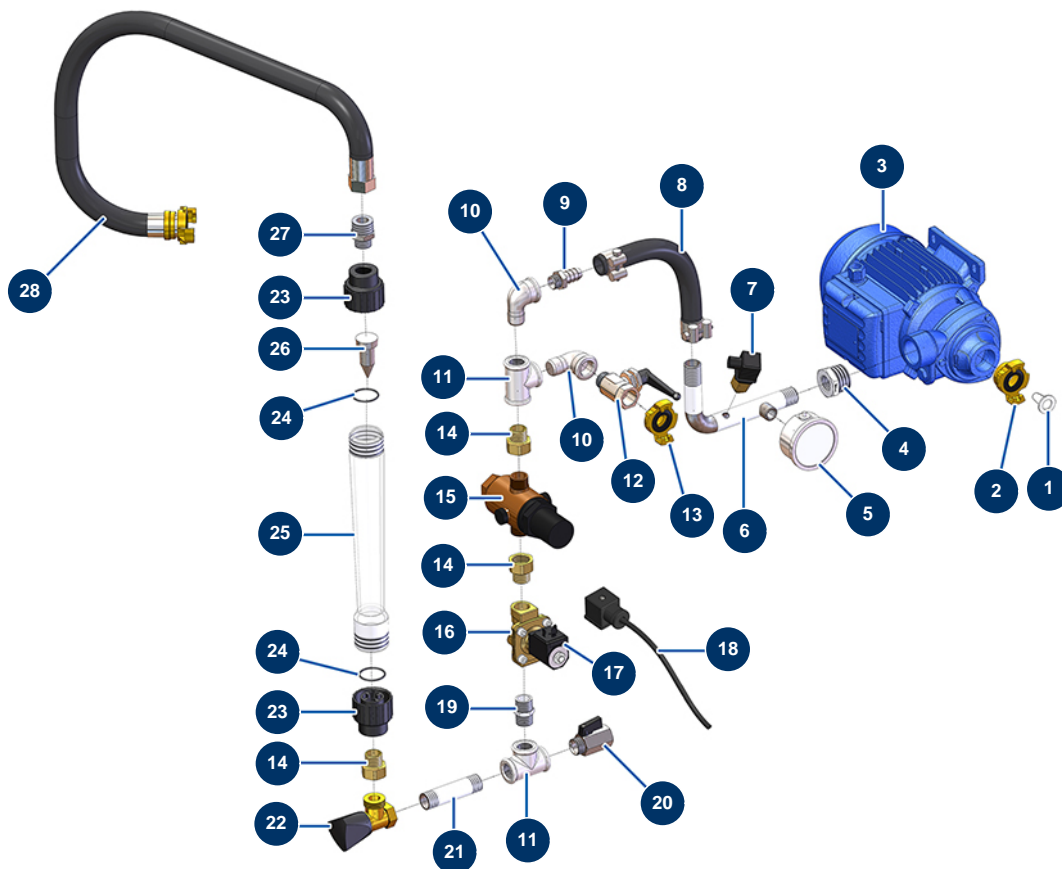

Détails des pièces

Pos.	Référence	Désignation
1	MI3A00100600	Stainless steel water filter
2	MI3A00100304	1" GEKA male coupling
3	MI3D00703002	400V TRI electropump
4	MI3G00524105	1" MaleC x 1/2" FemaleC galvanised reduction
5	MI3G00100141	0-10 bar manometer
6	MI7050001000	
7	MI3G00402103	Water pressure switch
8	MI3F00700211	
9	MI3G50300201	
10	MI3G00509202	90° galvanised elbow 1/2" MaleC x 1/2" FemaleC
11	MI3G00513002	Galvanised T F1/2" x F1/2" x F1/2"
12	MI3G01200502	Ball valve MF 1/2 black lever
13	MI3A00100302	1/2" outer threaded Geka coupling

Pos.	Référence	Désignation
14	MI3G01700100	
15	MI3G00904100	Water pressure regulator 0,5 to . bar
16	MI3G00301300	1/2 Parker solenoid valve
17	MI3G00301400	1/2 solenoid valve coil 24V
18	MI3G00300402	Solenoid valve coil connector
19	MI3G00528002	Galvanised nipple 1/2" MaleC x 1/2" MaleC
20	MI3G01200301	Black handle valve M1/2" x F1/2"
21	MI3G00553002	Galvanised nipple 1/2" M-M length 80 mm
22	MI3G01300201	Water flow adjustment tap
23	MI3G01100303	Flowmeter tube coupling 160/1600
24	MI3G01100305	Flow Meter Tube O-ring 160/1600
25	MI3G01100302	Flowmeter tube 160/1600 l/h
26	MI3G01100304	160/1600 flow meter tube float
27	MI3G50300704	3/4" MaleC x 1/2" MaleC low-pressure nipple
28	MI8002008002	Mixing chamber water supply hose ø 18 Lg. 400 mm

MIXPRO 50 STANDARD complete continuous mixing machine - 400V 50 Hz - Electrical box

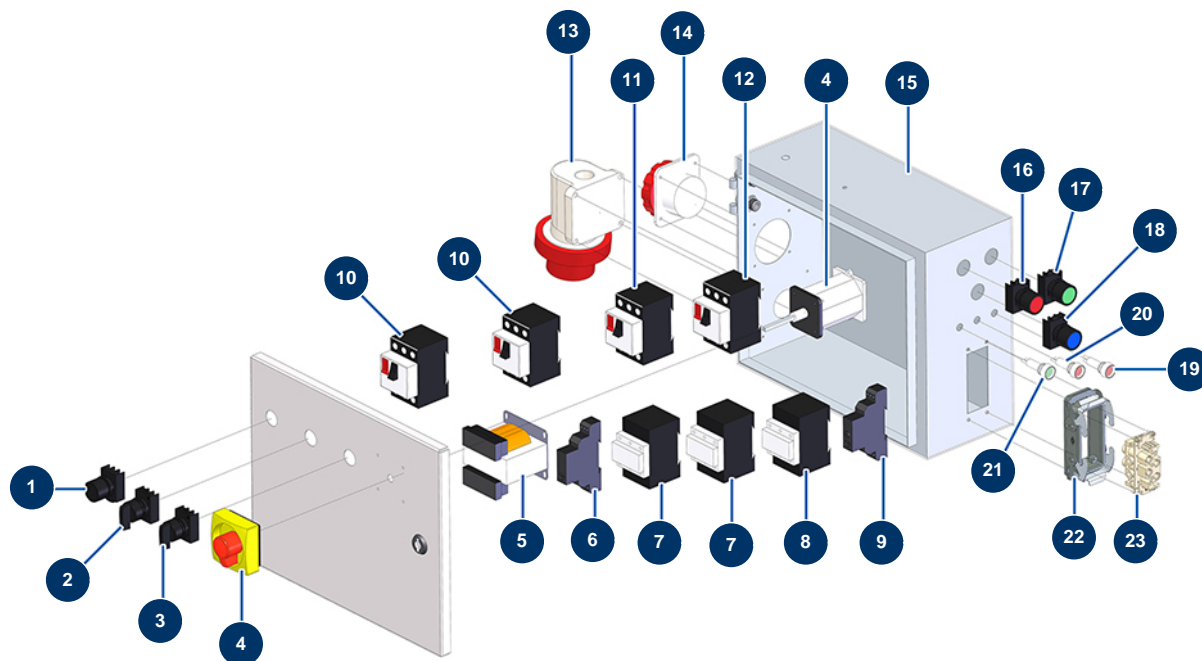

Détails des pièces

Pos.	Référence	Désignation
1	MI3C04000101	Black button ø 22 mm
2	MI3C04400800	
3	MI3C04400700	
4	MI3C04400207	
5	MI3C00500402	70/80VA 400/42/24/15V transformer
6	MI3C00601001	Phase monitor relay
7	MI3C00700117	4 KW 24V AC coil contactor
8	MI3C00700110	3RT10251A 7,5KW 24V AC coil contactor
9	MI3C03750400	Timer 2 delayed threads 24/230AC/DC
10	MI3C01040107	1,8/2,5A thermal contactor
11	MI3C01040110	10/16A thermal contactor
12	MI3C01040112	18/25A thermal contactor
13	MI3C03000305	Male socket on 3P+N+T 32A - GW base - 380V

Pos.	Référence	Désignation
14	MI3C02600203	3-pin+gr female inclined plug 16A GW 62231
15	MI3C00102805	15
16	MI3C04000104	Red button ø 22 mm
17	MI3C04000105	Green button ø 22 mm
18	MI3C04000100	Blue button ø 22 mm
19	MI3C04000106	Orange light indicator with cable 24V
20	MI3C04000107	Red light indicator with cable 24V
21	MI3C04000108	21
22	MI3C02800502	16-pin socket base with 2 levers
23	MI3C02700600	Female motor safety socket

MIXPRO 50 STANDARD complete continuous mixing machine - 400V 50 Hz - Spraying lance

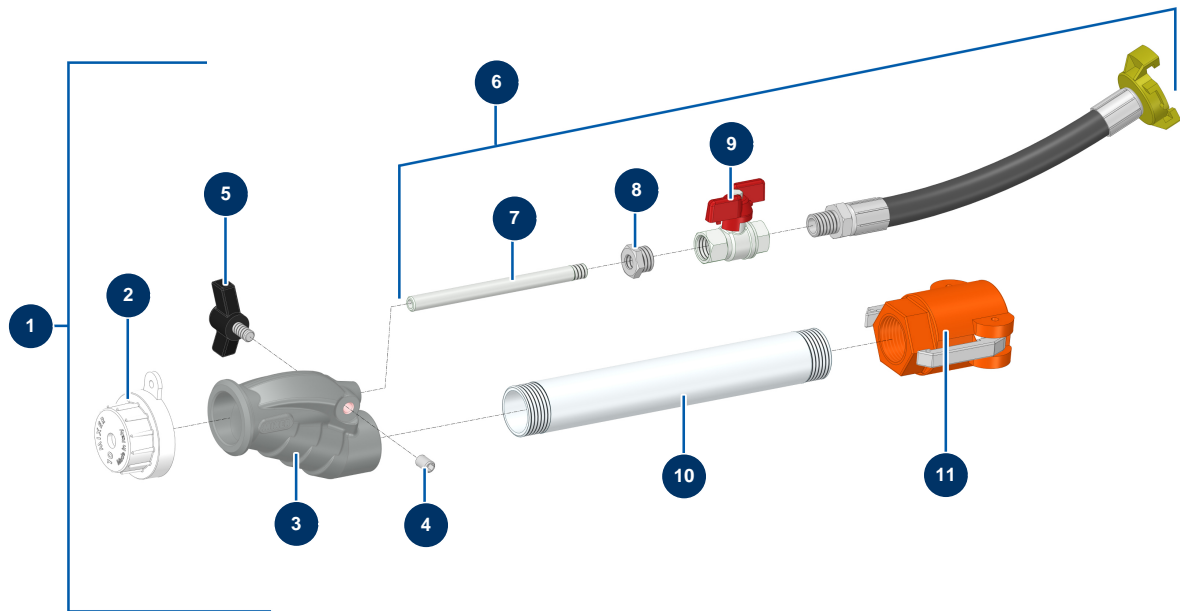

Détails des pièces

Pos.	Référence	Désignation
1	MI8010003005	MIXER standard Aluminium Lance
2	MI3F00200101	White spraying nozzle Ø 10 80SH
3	MI4916001000	Mixer straight lance head
4	14151	8 x 12 stainless steel socket head screw with flat tip
5	MI3T01505001	Mixer black Eye bolt diam 8
6	MI8010100001	Mixer aluminium standard spray lance air regulation kit
7	MI4907402000	Outer threaded air injector
8	MI3G50300102	8
9	MI3G01300103	9
10	MI4907441001	230 mm extension outer threaded tube
11	MI3A00300241	1" camlock polypro coupling, inner threaded 1"

MIXPRO 50 STANDARD complete continuous mixing machine - 400V 50 Hz - Hoses

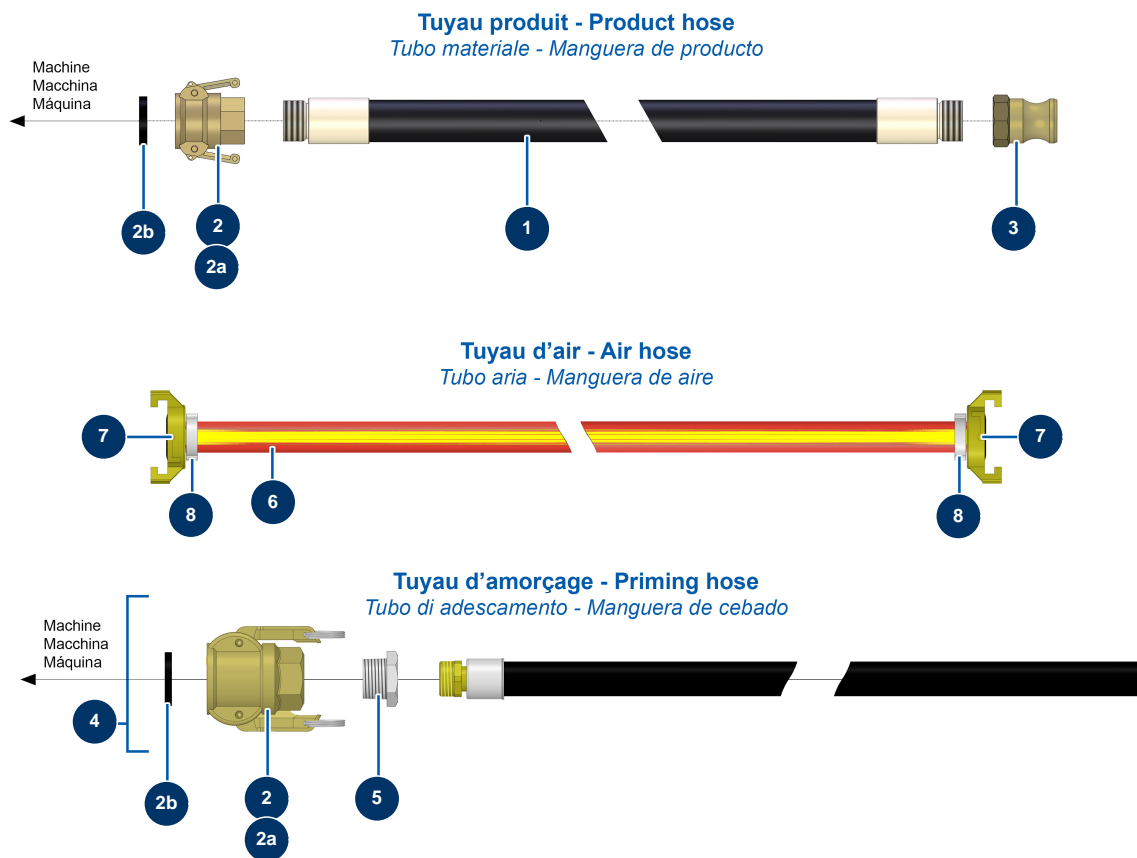

Détails des pièces

Pos.	Référence	Désignation
1	50014	25 x 15 m product hose outer threaded 1" without couplers
2	11950	1" camlock steel coupling, inner threaded 1"
2a	12978	Product and lance hose steel cam coupler - C.P 60
2b	70014	1" cam coupler gasket
3	11952	1"ø 27 steel adapter, inner threaded 1"
4	12012	Pouring product hose Ø 19 x 2 m - 1" coupling MIXPRO 28, 30, 50
5	90789	1" MaleC x 3/4 FemaleD low-pressure reduction
6	MI3F00700201	Yellow and red PVC hose ø 13 x 19 by the metre
7	MI3A00100102	Corrugated Geka coupling of 13
8	MI3G00200301	8