

## COMPACT-PRO 50 liquid screed machine - Electrical box

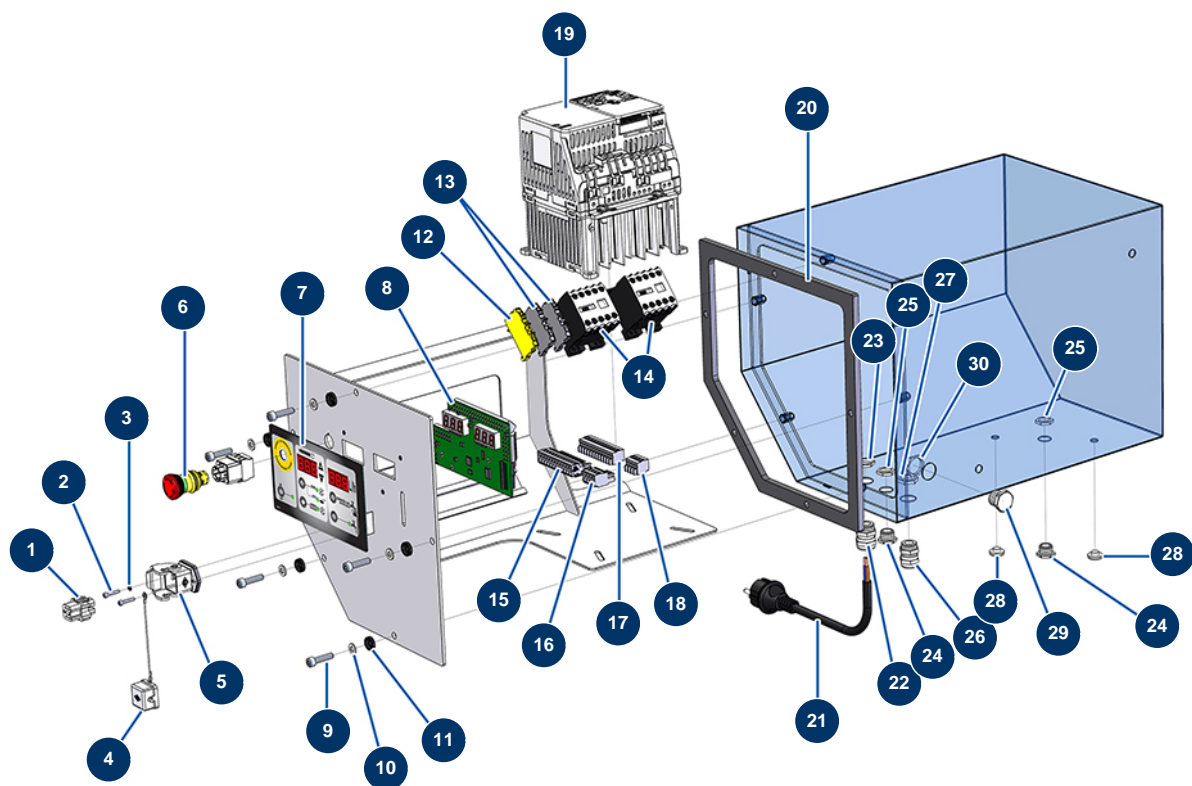

### Détails des pièces

Pos.	Référence	Désignation
1	11914	Female insert 4p + G
2	12250	3 x 16 cylindrical head screw
3	12108	ø 3 inox narrow washer
4	12535	2 PIV cover with MIXPRO 14 gasket
5	11915	Blowing machine insulating support 3 p + T - 1 lever
6	13015	Hanging EMERGENCY STOP button Ø16
7	13006	COMPACT PRO front with membrane
8	30672	COMPACT-PRO 30, 35 & 40 electronic card
9	80614	6 x 25 inox cylindrical head screw
10	70087	ø 6 inox narrow washer
11	80573	Hollow washer Ø 6
12	30038	Yellow and green conductive block 6 mm <sup>2</sup>
13	80467	Grey conductor block 4 mm <sup>2</sup>

Pos.	Référence	Désignation
14	11918	Coil contactor 24 Volt AC
15	11771	12 pins male connector
16	12754	4-pin male connector
17	11772	12 pins female connector
18	12755	4-pin female connector
19	80459	Inverter 230 V - 2.2 KW
20	11361	EUROPRO COMPACT-PRO 30 electric box gasket
21	90214	Power cable with molded plug 3G 2,5 mm <sup>2</sup>
22	30332	13mm nickel plated sealed cable gland
23	30054	Cable gland locknut of 13
24	80442	Electric plug for IM 16
25	11327	Cable gland locknut of M16
26	30040	Nickel plated watertight cable gland of 11 CEM
27	30333	Cable gland locknut of 11 CEM
28	80397	Water exhaust cork for electrical box
29	90567	Electrical plug of 11
30	30060	11mm cable gland nut