

X-PRO D85 spraying machine - Electrical box

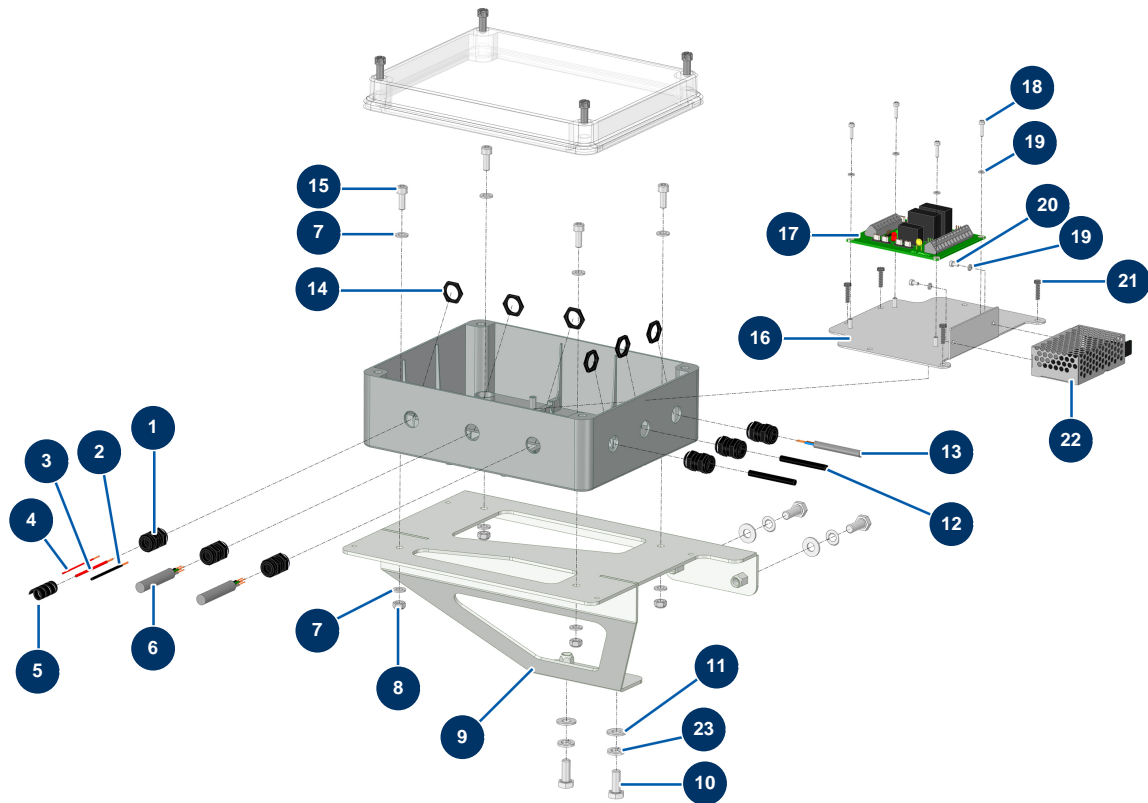

Détails des pièces

Pos.	Référence	Désignation
1	80445	Watertight cable gland of M16
2	30391	
3	60023	
4	30020	
5	80233	
6	11964	H05VVF 4G1 grey electrical cable by the metre
7	70087	ø 6 inox narrow washer
8	14217	M 6 nylstop inox nut
9	C23774	
10	30273	THEF 8 x 20 screw
11	80260	ø 8 inox medium washer
12	12120	Grid safety sensor for JETMIX, MIXPRO 14, 70 & 100
13	11973	Electrical cable H05VVF 2x1 / sold by the meter

Pos.	Référence	Désignation
14	11327	Cable gland locknut of M16
15	90157	M6 x 16 cylindrical head screw - CP 60
16	C24049	
17	12988	Safety electronic card - C.P 60
18	12249	3 x 12 cylindrical head screw
19	12108	∅ 3 inox narrow washer
20	13329	3 x 6 cylindrical head screw
21	310022	
22	15072	12VDC / 24VDC transformer
23	80269	Grower washer ∅ 8