

TURBISOL 164/2 blowing machine - Transmission (up to 05/2021)

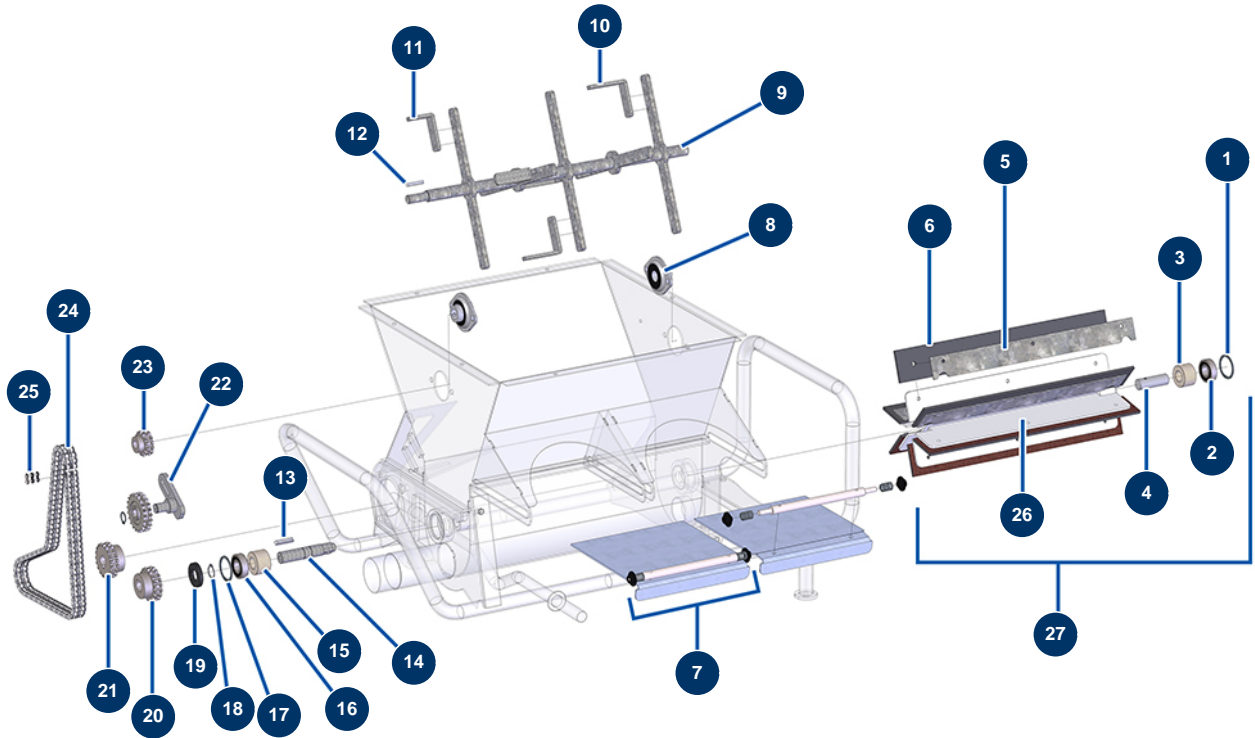

Détails des pièces

Pos.	Référence	Désignation
1	12210	Blowing machine distributor Ø 42 inner circlip
2	12209	TURBISOL 56 and 112 blowing machine distributor bearing
3	11907	Felt gasket Ø 20 x 40 for TURBISOL 56, 112 & 164 blowing machine
4	M10014	Version 2 blowing machine distributor short axis from AUGUST 2010
5	C20040	Blowing machine paddle fixing detachable support
6	11992	Set of 6 foam-rubber blades for version 2 blowing machine distributor
7	12315	TURBISOL 112 product flow complete adjustment trapdoor
8	11900	Flange bearing ø 20 - 2 points for blowing machine
9	C22560	TURBISOL 112 & 164 blowing machine mixing shaft
10	C20691	TURBISOL mixing claw, 70 mm
11	C20692	TURBISOL mixing claw, 45 mm
12	12001	5 x 5 x 28 parallel key with round end
13	12000	6 x 6 x 29 parallel key with round end

Pos.	Référence	Désignation
14	M10013	Version 2 blowing machine distributor long axis from AUGUST 2010
15	11907	Felt gasket Ø 20 x 40 for TURBISOL 56, 112 & 164 blowing machine
16	12944	TURBISOL 112 blowing machine distributor bearing with conical holder
17	12210	Blowing machine distributor Ø 42 inner circlip
18	12318	Ø 20 outer circlip
19	80613	Spi seal 20 x 42 x 7
20	11986	Version 2 blowing machine 19-tooth double sprocket
21	11985	Version 2 blowing machine 18-tooth double sprocket
22	30666	Blowing machine transmission complete chain tensioner
23	11984	Version 2 blowing machine 13-tooth double sprocket
24	14559	
25	11989	Version 2 blowing machine double chain quick fit attachment
26	C20290	Version 2 blowing machine rotating distributor from AUGUST 2010
27	12291	