

TURBISOL 56/2 blowing machine - Transmission (up to 05/2021)

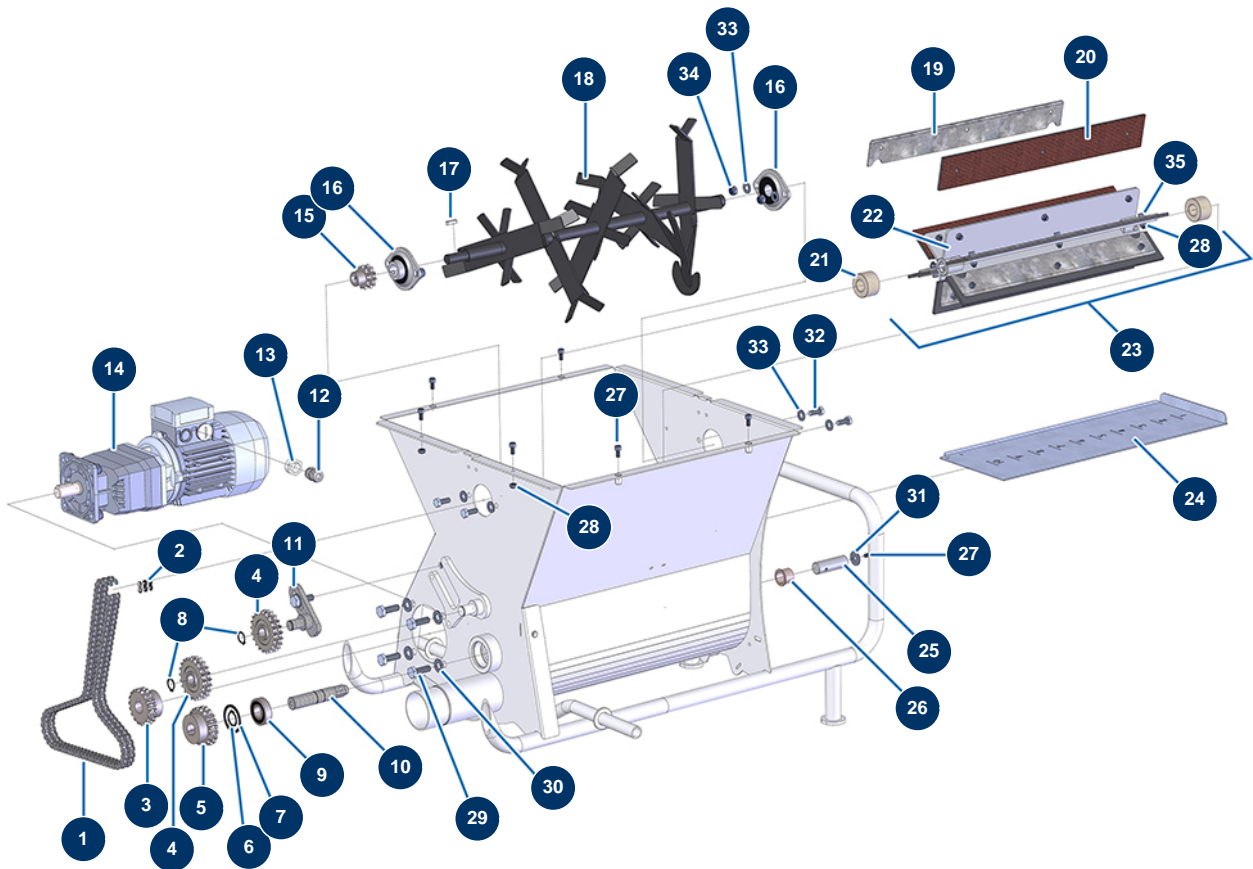

Détails des pièces

Pos.	Référence	Désignation
1	14398	Blowing machine triple chain Lg. 934 mm (98 links) with quick coupling
2	11989	Version 2 blowing machine double chain quick fit attachment
3	11985	Version 2 blowing machine 18-tooth double sprocket
4	11987	Version 2 blowing machine 21-tooth idler sprocket
5	11986	Version 2 blowing machine 19-tooth double sprocket
6	12318	Ø 20 outer circlip
7	12210	Blowing machine distributor Ø 42 inner circlip
8	11991	Ø 16 outer circlip
9	12944	TURBISOL 112 blowing machine distributor bearing with conical holder
10	M10013	Version 2 blowing machine distributor long axis from AUGUST 2010
11	C20046	Blowing machine transmission single chain tensioner
12	30040	Nickel plated watertight cable gland of 11 CEM
13	80446	Cable gland reduction M 25-11

Pos.	Référence	Désignation
14	11908	Geared motor 0,55 kW - TC122 - R29,5 - 1400 rpm - 400V
15	14522	11-tooth double sprocket, pitch 9.525 Version Evo 2
16	11900	Flange bearing ø 20 - 2 points for blowing machine
17	12001	5 x 5 x 28 parallel key with round end
18	C22559	
19	C20040	Blowing machine paddle fixing detachable support
20	11992	Set of 6 foam-rubber blades for version 2 blowing machine distributor
21	11907	Felt gasket Ø 20 x 40 for TURBISOL 56, 112 & 164 blowing machine
22	C20290	Version 2 blowing machine rotating distributor from AUGUST 2010
23	12291	
24	C20023	TURBISOL 56 flow adjustment flap
25	M10014	Version 2 blowing machine distributor short axis from AUGUST 2010
26	11904	Blowing machine 20 x 24 x 20 small flange bearing
27	90157	M6 x 16 cylindrical head screw - CP 60
28	14217	M 6 nylstop inox nut
29	30258	THEF 10 x 30 screw
30	80261	ø 10 inox medium washer
31	80262	Very large inox washer Ø 6
32	30273	THEF 8 x 20 screw
33	80260	ø 8 inox medium washer
34	13980	M 8 nylstop inox nut
35	90996	6 x 20 inox cylindrical head screw