

EUROPROLAV 15-250 TH.2 HONDA washer - Motorization

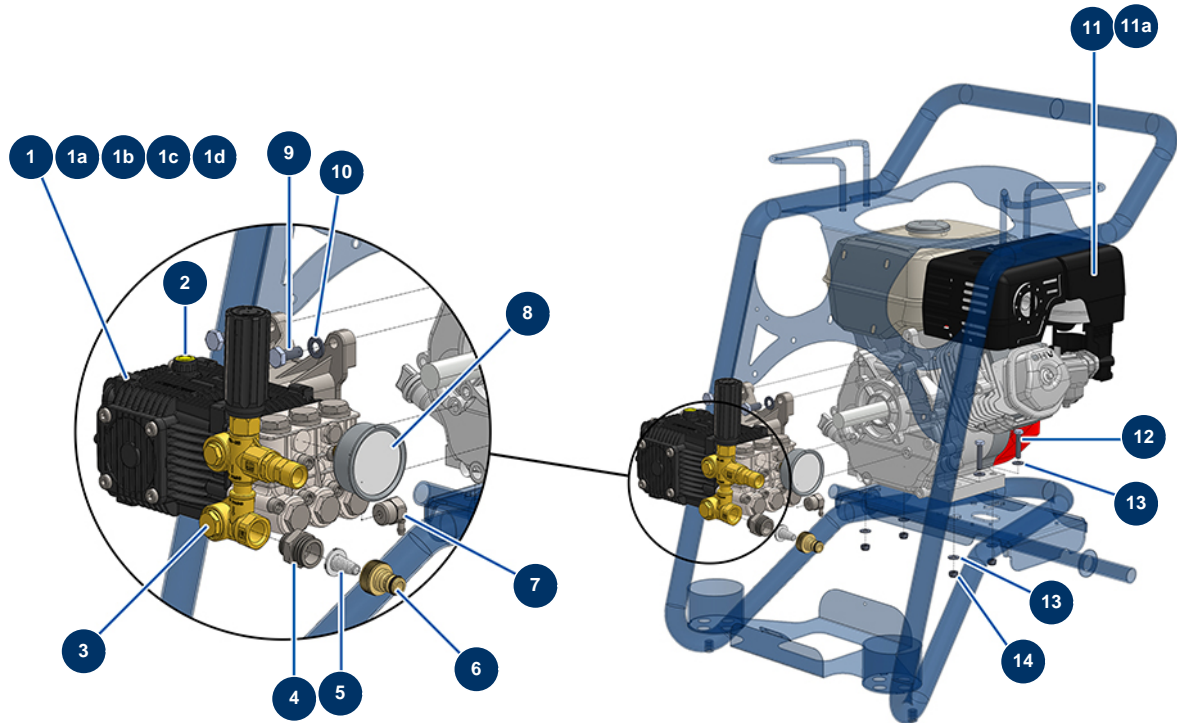

Détails des pièces

Pos.	Référence	Désignation
1	13033	Pump 15 litres 250 bar 3,400 rpm
1a	AN1828	RK 15-250 pump valves kit
1b	AN2757	RK 15-250 & 18-280 pump pistons kit
1c	AN1856	RK 15-250 pump oil seal gaskets kit
1d	AN1857	RK 15-250 & 18-280 pump water seal gaskets kit
2	AN880130	10-130 ECI,12-180, 15-200, 15-230 & 18-200 washer pump oil gauge
3	12041	Integrated return bypass 250 bars
4	11891	1/2" MaleD x 3/4" MaleD low-pressure nipple
5	80128	Filter for 3/4" brass quick connector
6	80124	Inner threaded 3/4" quick connector
7	90295	1/2" thermostatic valve
8	90433	63 mm oil manometer 1/4 conical 0 to 400 bar
9	30257	THEF 10 x 25 screw

Pos.	Référence	Désignation
10	30280	∅ 10 inox narrow washer
11	10037	Petrol motor HONDA GX 390K1 QX-Q4-OH 13 HP
11a	14685	VANGUARD 14 HP thermal motor
12	30250	THEF 8 x 40 screw
13	80260	∅ 8 inox medium washer
14	13980	M 8 nylstop inox nut