

X-PRO D200 liquid screed machine - Pump

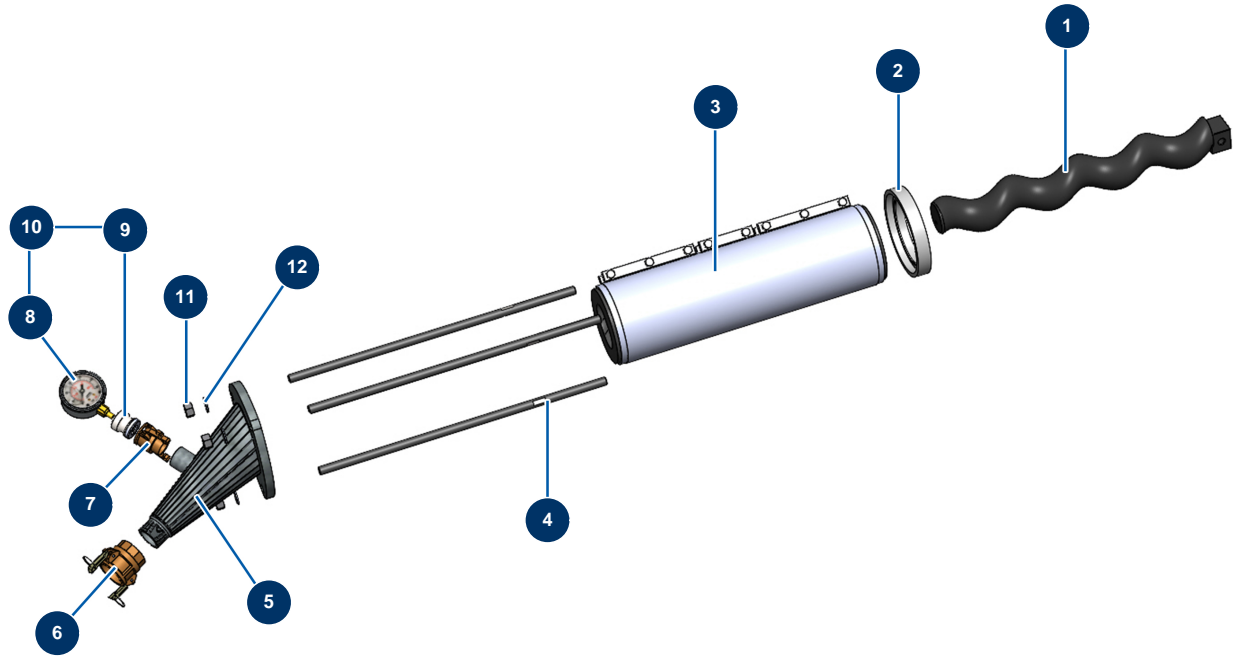

Détails des pièces

Pos.	Référence	Désignation
1	MI7009500700	MIXER 2L8 pump rotor with square and holed head
2	20178	X-PRO D200 2L8 stator flange
3	MI3F00600100	MIXER 2L8 SX 60SH adjustable pump stator
4	M10440	700 mm fastening tie rod for CP 60
5	C23060	
6	12364	2" camlock steel coupling, inner threaded 2" - CP 60
7	20070	1"1/4 camlock steel coupling, outer threaded 1"1/4
8	20154	Oil radial manometer 1/2" conical 100 mm - 0 to 60 bar
9	20062	X-PRO machine manometer adapter
10	20173	
11	12473	M 20 nut
12	10141	ø 20 inox narrow washer