

X-PRO D200 liquid screed machine - Transmission

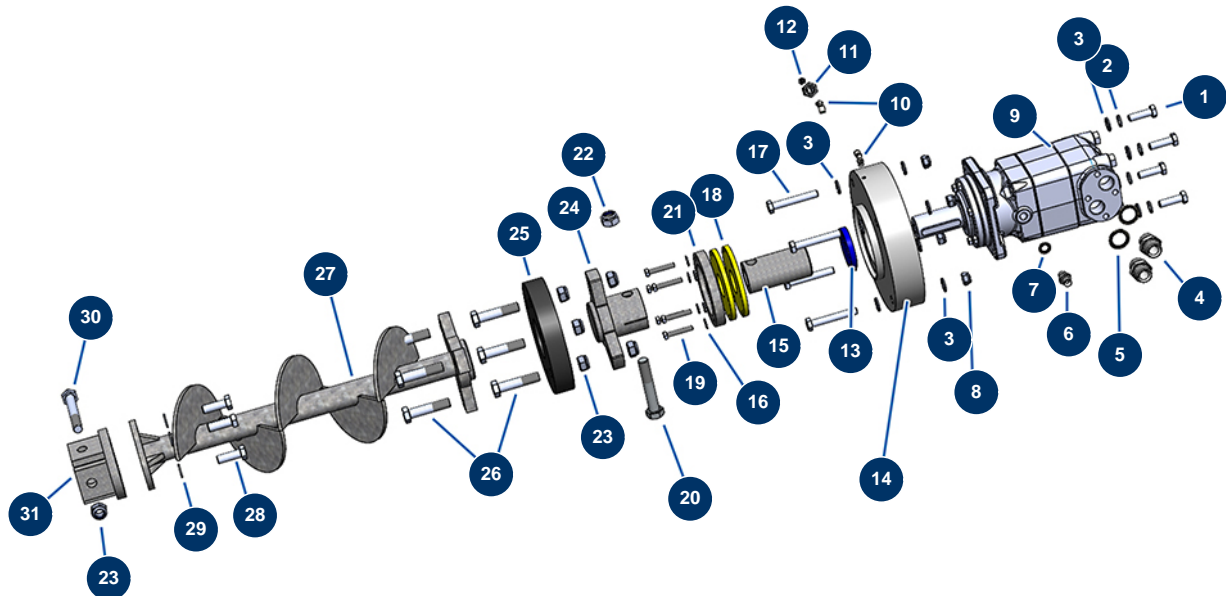

Détails des pièces

Pos.	Référence	Désignation
1	12928	THEF 12 x 40 screw
2	12462	Grower washer ø 12
3	30281	ø 12 inox narrow washer
4	90774	3/4" MaleD x 3/4" MaleD high-pressure nipple
5	12573	Steel gasket for 3/4" hollow screw with lip
6	90703	1/4" MaleD x 1/4" MaleD high-pressure nipple
7	91016	Steel gasket for hollow screw with 1/4 lip
8	10051	M 12 nylstop nut
9	20208	OMT 400 X-PRO D200 hydraulic motor
10	30124	Corrugated Legris coupling M1/8" Ø 6
11	20159	
12	20044	1/8" M straight lubricator
13	20042	Spi seal 55 x 72 x 10

Pos.	Référence	Désignation
14	20207	OMT 250 X-PRO D140 hydraulic motor flange
15	20056	X-PRO 140, 200 & CP 100 drive shaft
16	30256	∅ 8 inox narrow washer
17	20047	THPF screw 12 x 80 raw steel 12.9
18	20058	X-PRO machine tank bottom gasket
19	11798	THEF 8 x 45 screw
20	20040	18 x 100 THPF screw
21	20059	X-PRO machine seal flange
22	20039	M 18 nylstop nut
23	90491	M 16 nylstop nut
24	20180	X-PRO D200 motor/transmission shaft coupling
25	14843	Transmission shaft elastic coupling - X-PRO D200
26	20369	THEF 16 x 70 screw
27	20179	X-PRO D200 tank bottom drive shaft
28	20263	THEF 14 x 25 screw
29	20293	127 ∅ 14 grower washer
30	20673	DIN 6914 16 x 110 screw
31	20181	X-PRO D200 transmission rotor/shaft coupling