

## MIXPRO 50 STANDARD complete continuous mixing machine - 400V 50 Hz - Mixing group

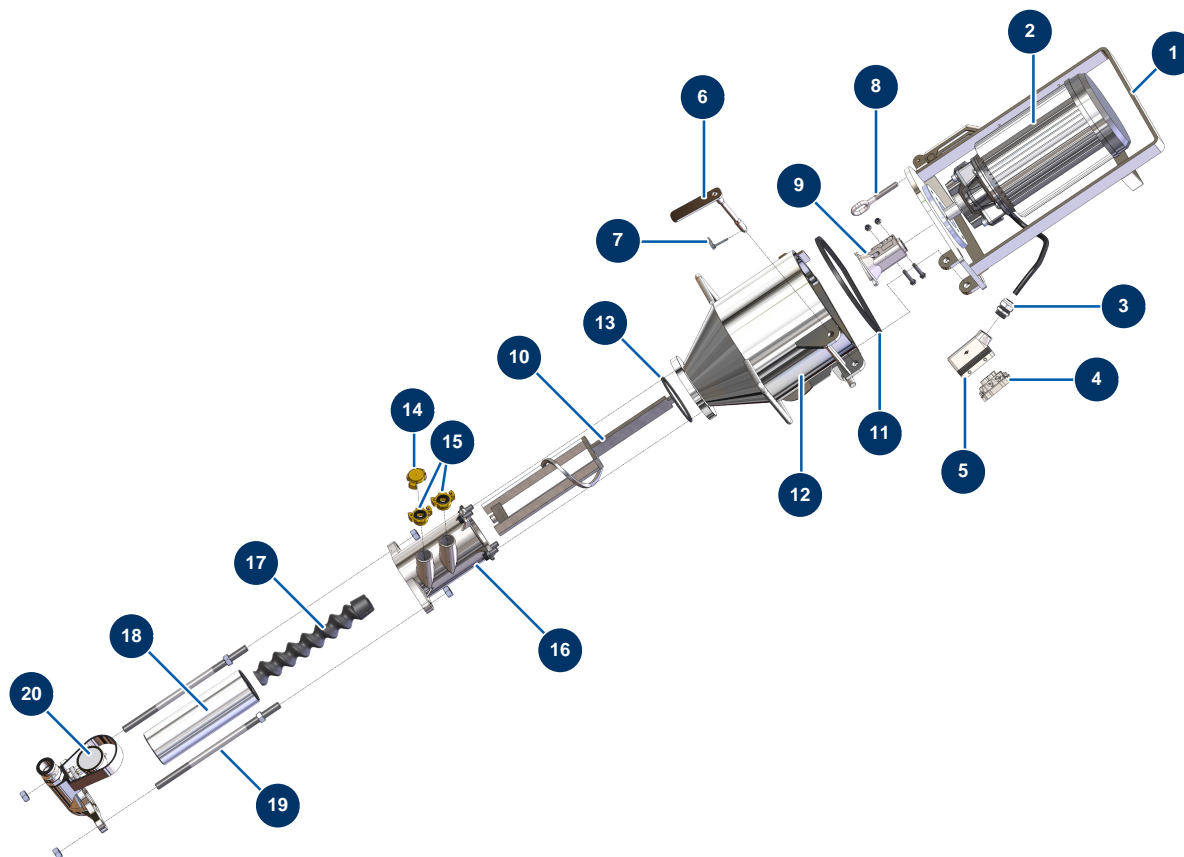

### Détails des pièces

Pos.	Référence	Désignation
1	MI7011003000	PLUS Motor Support
2	MI3D00420100	CAMIX 5,5 KW 400V geared motor
3	MI3C04200208	PG21 cable gland
4	MI3C03100400	Male motor safety socket
5	MI3C02800100	Mobile Base
6	MI7018006000	Engine locking axis
7	MI3T01200101	Clip pin
8	MI3T01000400	Motor Closing Ring
9	MI700600600S	PLUS TRI/ MIXPRO 50 motor coupling
10	MI700301940B	PLUS/G4 heavy mixer blue RAL 5002
11	MI3G01000151	Motor support gasket by the metre
12	MI701400200S	MIXER PLUS mixing chamber

<b>Pos.</b>	<b>Référence</b>	<b>Désignation</b>
13	MI3G01000301	O-ring
14	MI3A00100401	Geka coupling plug
15	MI3A00100304	1" GEKA male coupling
16	MI7021004000	MIXPRO 28 mixing chamber
17	MI7009049200	MIXER 1 D6-3 long life pump rotor
18	MI3F00502200	MIXER 1 pump stator
19	MI8023003000	M16 tie rod L = 350 mm + screws
20	MI8012005000	PLUS/MUSTANG complete pump head